

NeuroMatrix® NM6403 DSP



NeuroMatrix® NM6403 is a high performance dual-core microprocessor with combination of VLIW/SIMD architectures.

The architecture includes two main units: 32-bit RISC Core and 64-bit VECTOR co-processor to support vector operations with elements of variable bit length (Patent US 6,539,368 B1). There are two identical programmable interfaces to work with any memory types as well as two communication ports hardware compatible with TI DSP TMS320C4x which permit to build multi-processor systems.

Features:

- clock frequency - 40 MHz (25ns instruction cycle time);
- Technology used CMOS 0.5 mkm.;
- BGA256 package;
- low voltage operation, from 3.0 V to 3.6 V;
- power consumption @50 MHz about 1.6 W;
- temperature range: -60...+85 C.

RISC-Core

- 5-stage pipelined 32-bit RISC;
- processor instructions are 32 and 64 bit wide (usually two operations are executed by each instruction);
- two address generation units, address space - 16 GB;
- two 64 bit programmable interfaces with SRAM/DRAM shared memory;
- data format: 32-bit digit integers;
- registers:
 - 8 of 32 bit general purpose registers;
 - 8 of 32 bit address registers;
 - special control and state registers;
- two high speed I/O communication ports of a byte width hardware compatible with those of TMS320C4x.

VECTOR co-processor

- 1-64 bit word length of vector operands and the products;
- data format: integer data packed into 64-bit blocks in the form of variable length words from 1 to 64 bits each;
- hardware support of vector-matrix or matrix-matrix multiplication;
- On-chip saturation functions;
- On-chip three 32*64 bit RAM blocks.

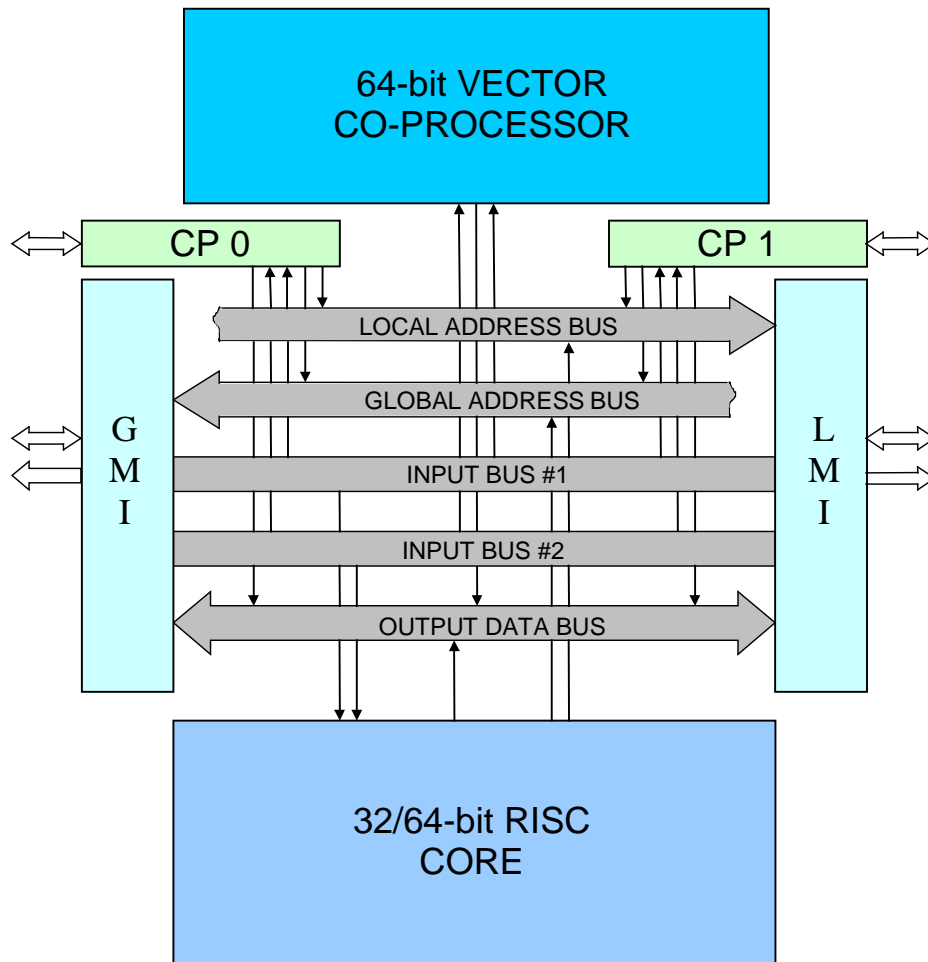

Applications:

Accelerators for PCs and workstations for:

- neural net emulation;
- signal processing;
- image processing;
- acceleration of vector and matrix calculations;
- telecommunications;
- embedded systems;
- basic block for building large super parallel computing systems.

Performance:

- scalar operations:
 - 40 MIPS;
 - 120 MOPS for 32 bit data;
- vector operations:
 - from 40 to 11.500+ MMAC (million multiplication and accumulation per second);
- I/O and interfaces:
 - two programmable external memory 64 bit interfaces have up to 800 MB/sec. throughput;
 - I/O communication ports up to 20 MB/sec. throughput each.